



- Each station has:
- Magnetic stirrer
- Dual jacket reactor
- pH electrode
- pH regulator by 2 peristaltic pumps
- 1 Thermometer
- 2 Gas inlets
- 1 Outlet by p.pump
- 1 Septum inlet
- 1 Air sparger
- 1 Exhaust cooler
- 1 Reagent p.pump
- 1 Reagent flask
- 1 Drain outlet cap

- Chaque poste a:
- Agitateur magnétique
- Réacteur double chambre
- pH électrode
- pH régulateur par 2 pompes peristaltiques
- 1 Thermomètre
- 2 Entrées pour gas
- 1 Sortie Pompe péris.
- 1 Entrée septum
- 1 Difusor d'air
- 1 Réfrigérant
- 1 Pompe Pérís. réactifs
- 1 Flacon pour réactif
- 1 Robinet à vidange

1L COMPLET KIT
REAX-2124

1L COMPLET KIT
REAX-2125

6x 1L-2L
 FERMENTER
 FERMENTATEUR
 FERMENTADOR
 FERMENTADOR

2L COMPLET KIT
REAX-2126

2L COMPLET KIT
REAX-2127

- Cada estação tem:
- Agitador magnético
- Reactor dupla câmara
- pH elétrodo
- pH regulador com 2 bombas peristálticas
- 1 Termómetro
- 2 Entradas para gas
- 1 Saída bomba Peris.
- 1 Entrada Septum
- 1 Difusor de ar
- 1 Condensador
- 1 Bomba Per. reagente
- 1 Frasco reagente
- 1 Tomeira drenagem

- Cada puesto tiene:
- Magnetoagitador
- Reactor encamisado
- pH electrodo
- pH regulador por 2 bombas peristálticas
- 1 Termómetro
- 2 Entradas de gas
- 1 Salida con bomba
- 1 Entrada Septum
- 1 Aireador
- 1 Refrigerante
- 1 Bomba P.reactivo
- 1 Frasco reactivo
- 1 Grifo desague

COMMON: Basic unit, 1 Base flask, 1 Acid flask, 6 flow-meter rack gas 1, 6 flow-meter rack gas 2, 6 flow-meter rack air, 1 °C probe, 1 air filter, Bath.
 COMMUN: Basic unit, 1 Flacon base, 1 Flacon acide, 1 rack 6 rotamètres gas 1, 1 rack 6 rotamètres gas 2, 1 rack 6 rotamètres aire, 1 sonde °C, 1 filtre d'aire, Bain
 COMUM: Basic unit, 1Frasco Base, 1 Frasco ácido, 1 rack 6 rotámetros gas 1, 1 rack 6 rotámetros gas 2, 1 rack 6 rotámetros ar, 1 sonda °C, 1 filtro de ar, Banho
 COMUN: Basic unit, 1Frasco Base, 1 Frasco ácido, 1 rack 6 rotámetros gas 1, 1 rack 6 rotámetros gas 2, 1 rack 6 rotámetros aire, 1 sonda °C, 1 filtro de aire, Baño

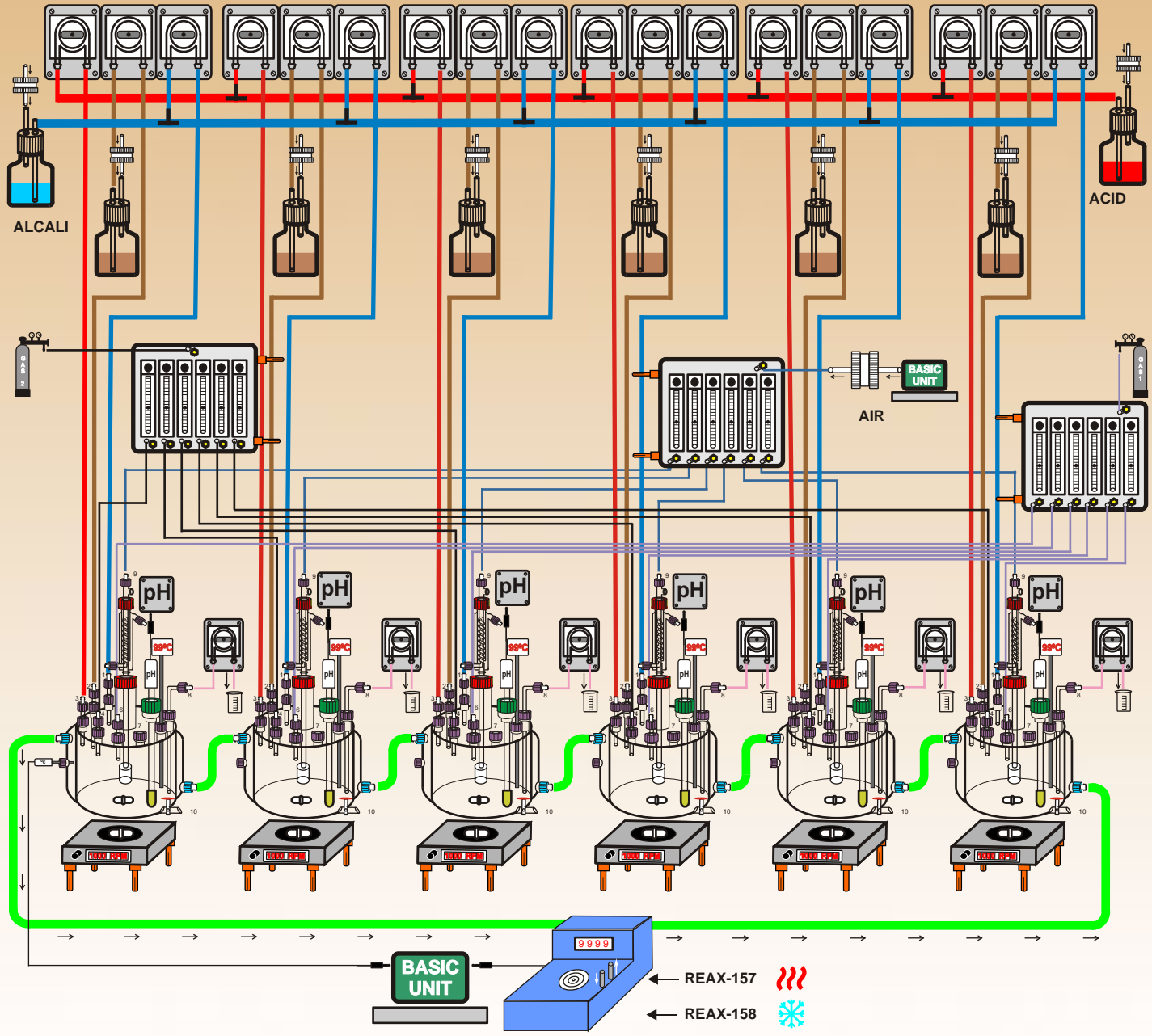

BASIC UNIT
 Regulation included in the Basic Unit REAX-2000
 Régulation incorporé dans l'Unitée Basique REAX-2000
 Regulação incorporada na Unidade Basica REAX-2000
 Regulación incluida en la Unidad Básica REAX-2000

